

530-0100 e-FOB Transmitter



DESIGNED FOR:

- Replacement components of TriMark's e-ASK systems

INSTALLATION:

- e-FOB receiver is easily installed with (2) #6 or M3 screws (not included) and can be mounted in a concealed location
- Standard 12V DC power



Global Locations:

TriMark Corporation
500 Bailey Avenue
P.O. Box 350
New Hampton, Iowa 50659
United States
Tel: 641-394-3188
Fax: 641-394-2392
1-800-447-0343
www.trimarkcorp.com

TriMark Europe
Unit 3 Sence Court
Bardon Hill
Coalville
Leicestershire LE67 1GZ
United Kingdom
Tel: +44(0)1530 512460
Fax: +44(0)1530 512461
www.trimarkeu.com

TriMark (Xuzhou)
Building A5 Jingwu Road
Xuzhou Economic
Development Zone
Xuzhou, Jiangsu
221004 PR China
Tel: +86 516 8773 0018
Fax: +86 516 8773 0058
www.trimarkcn.com



TriMark. Interactive. Product. Selector



TriMark



TriMark Corporation



TriMark Corporation

3/24-11

AVAILABLE:

- Three different programming functions; standard mode, cargo mode and sustained mode. Modes provide customized remote fob transmitter use.
 - ◊ Standard mode allows for the lock/unlocking of doors plus panic mode and one auxiliary output (controls lighting, opens compartment etc.).
 - ◊ Cargo mode allows for the lock/unlocking of main personnel doors plus independent control of many cargo/compartment doors.
 - ◊ Sustained mode allows for the lock/unlocking of doors plus continuous output control with lower buttons pressing.
- 4-button standard and cargo fob, 2-button fob, and wall mount
- Customized graphics possible (buttons and logos - please inquire)

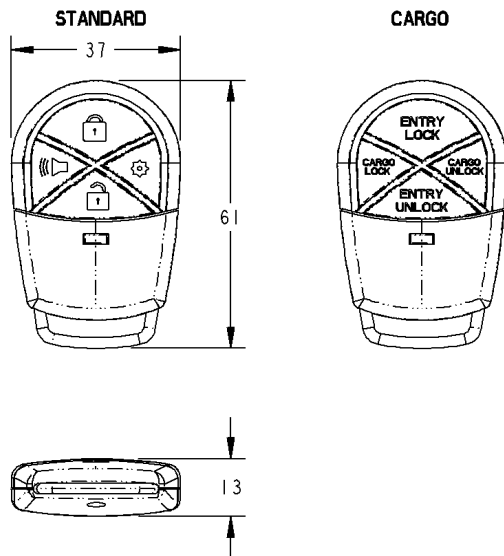

Design Patent No. D590,780 / D589,000

Individual part dimensions are for reference only. Refer to individual part drawings for complete dimensions, specifications, and installation procedures. Engineering assistance and application drawings are available.

For more information visit
www.trimarkcorp.com

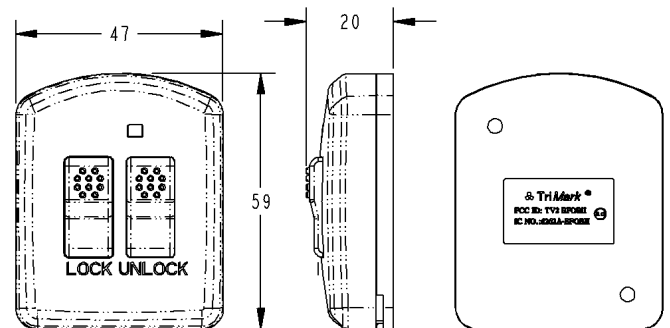
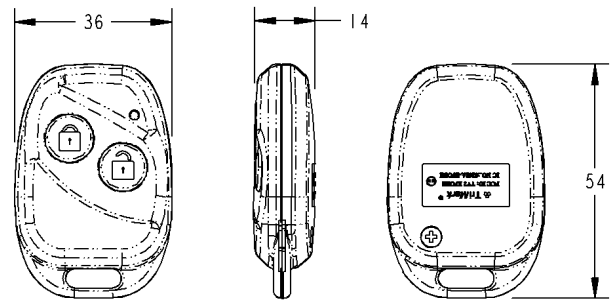

WARNING:

Immediately dispose of used batteries and keep away from children. Do NOT dispose of batteries in household trash.

Even used batteries may cause severe injury or death.

Call a local poison control center for treatment information.

⚠ WARNING

- **INGESTION HAZARD:** This product contains a button cell or coin battery.
- **DEATH** or serious injury can occur if ingested.
- A swallowed button cell or coin battery can cause **Internal Chemical Burns** in as little as **2 hours**.
- **KEEP** new and used batteries **OUT OF REACH OF CHILDREN**
- **Seek immediate medical attention** if a battery is suspected to be swallowed or inserted inside any part of the body.

